

MC12P Reference Manual



Reference Manual

MC12P

MC12P Reference Manual



DECLARATION OF CONFORMITY:	4
1: MULTI FILLING SYSTEM	5
1.1 System design	5
1.2 Control system	5
1.3 RS485 multidrop network.....	6
2: INSTALLATION	7
2.1 Unpacking and inspection.....	7
2.2 Connections	7
3: CONTROL	8
3.1 Display	8
3.2 Keypad.....	9
4: PROGRAMMING	10
4.1 Starting the MC12P	10
4.2 Password Protection	10
4.3 Programming.....	11
4.4 Parameters	11
4.5 Programs	11
4.6 General information on the programming of the MC12P	11
5: DESCRIPTION OF FUNCTIONS	12
5.1 List of functions	12
5.2 Function 1, volume.....	13
5.3 Function 2, tube diameter	14
5.4 Function 3, velocity	15
5.5 Function 4, acceleration/deceleration	16
5.6 Function 5, reversing	17
5.7 Function 6, batch size	18
5.8 Function 7, delay.....	19
5.9 Function 8, completed fills	20
5.10 Function 9, specific gravity.....	20
5.11 Function 10, output rate	21
5.12 Function 11, accumulated volume	21
5.13 Function 12, maximum flow	22
5.14 Function 16, pumping direction	22
5.15 Function 17, timer 1	23
5.16 Function 18, timer 2	23
5.17 Function 19, timer 3	24
5.18 Function 20, operator number.....	25
5.19 Function 21, batch number	25
5.20 Function 22, start log	26
5.21 Function 23, stop log.....	27
5.22 Function 24, print log	27
5.23 Function 25, delete log.....	30
5.24 Function 26, log status.....	30
5.25 Function 29, print parameters	31
5.26 Function 31, save program	33
5.27 Function 32, load program	34
5.28 Function 33, delete program	35
5.29 Function 34, print programs	36
5.30 Function 35, free memory capacity	37
5.31 Function 40, mode	38
5.32 Function 41, select filler	40

MC12P

Reference Manual



Flexicon a.s.
denmark

Frejasvej 2-6
DK-4100 Ringsted
Tel. +45 57 67 11 55
Fax +45 57 67 05 41
flexicon@flexicon.dk · www.flexicon.dk

5.33 Function 42, set date	41
5.34 Function 43, set time.....	43
5.35 Function 44, display time and date	43
5.36 Function 45, display drive version.....	44
5.37 Function 46, select language	44
5.38 Function 47, printer set-up	45
5.39 Function 48, RS232 set-up	47
5.40 Function 49, Balance set-up	47
5.41 Function 51, filling needle set-up	50
5.42 Function 53, drive deactivation	54
5.43 Function 58 Set Passwords	55
5.44 Function 59 Change access level	55
5.45 Function 60, Ext. Input Mode	56
5.46 Function 70, Capacity format	56
5.47 Function 71, flow rate format	57
5.48 Function 72, Volume format.....	57
5.49 Function 80, reset memory	58
5.50 Function 86, complete memory reset.....	58
6: DAILY USE	59
6.1 Used as a dispenser	59
6.2 Terminate dispensing.....	60
6.3 Used as a transfer pump.....	60
7: CALIBRATION	61
7.1 Calibration with measuring cylinder	61
7.2 Calibration with balances	62
7.3 Calibration of grams with balance	63
7.4 Recalibration	64
7.5 Calibration in parallel mode	65
7.6 Calibration in serial mode	66
7.7 Dynamic recalibration:	67
7.8 Fill on balance.....	68
8: CLEANING AND MAINTENANCE.....	69
8.1 Daily cleaning.....	69
8.2 Sterilisation	69
8.3 Maintenance	69
9: INTERFACE.....	70
9.1 "port 1", Fig. 80.1	70
9.2 "expansion", Fig. 80.2	70
9.3 "external GO", Fig. 80.3	71
9.4 "external 1", Fig 80.4.....	71
9.5 "RS-232/1", Fig. 80.5 9.6 "RS-232/2", 80.6.....	71
9.7 "net", Fig. 80.7.....	71
9.8 Change of voltage.....	72

MC12P Reference Manual



Declaration of conformity:

We Flexicon A/S
Frejasvej 2-6
DK-4100 Ringsted

declare on our sole responsibility that the product:

MC12P Master Controller

to which this declaration relates is in conformity with the following standard(s):

EN 292:.	Safety of Machinery: Basic Concepts & General Principles of design
EN 50081-1:	Generic Standard for Emission
EN 50082-1:	Generic Standard for Immunity

according to the provisions in the Directives:

98/37/EEC, 91/368/EEC and 93/44/EEC:.	Machine-directive
73/023:	Low Voltage-directive.
EMC 89/336/EEC	

Flexicon®
denmark

Model:

S/N:

Supply:

Year:

CE Made in Denmark

Ringsted, Denmark

October 2003

Mads Ulric Jensen
Signature.

MC12P Reference Manual



1: MULTI FILLING SYSTEM

1.1 System design

Flexicons Multi Filling System (FMFS) offers several different types of filling stations for the filling of thin and thick liquids from alcohol to cream products.

Depending on the choice of filling station, fills from 0.05 ml up to more than 1 litre can be performed.

The FMFS is a modular system and the choice of units depends on the application. The following parameters should be considered:

- A: Filling volume
- B: Viscosity
- C: Output capacity

Please contact Flexicon A/S or your local supplier for advice on the optimum solution for individual requirements.

For the purpose of this manual, a filling station is called a **DRIVE**, regardless of type.

1.2 Control system

For control of the selected drive(s), Flexicon A/S has developed a programmable control unit called MC12P the operation of which will be described in this Reference Manual.

The MC12P uses an RS485 multidrop network to communicate with the connected drives.

The drives may also be controlled from a PC; in that case the PC communicates through an RS485 multidrop network as specified in the Flexicon protocol.

Please contact Flexicon A/S or your local supplier for information on the protocols for the different drives.

MC12P Reference Manual



1.3 RS485 multidrop network

Up to 16 drives may be connected to the Flexicon network. The maximum length of the network is 500 meters.

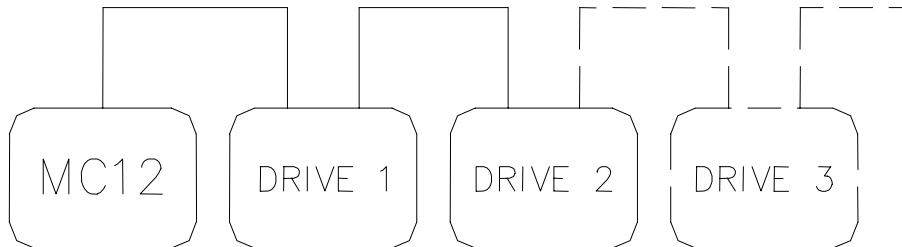

Fig. 1

The network is physically connected through special Flexicon communication cables marked "type 3". The MC12P is connected via a cable 3 to the first drive of the system, and subsequently the individual drives are inter-connected with a cable 3. The last drive is provided with a terminator which terminates the network.

It is important that each drive is allocated an individual address in order that the MC12P can identify individual drives.

Address	1	2	3	4	5	6	7	8	9	10	11	12	13	14	15	16
SW1	1	0	1	0	1	0	1	0	1	0	0	1	0	1	1	0
SW2	1	1	0	0	1	1	0	0	1	1	0	1	1	0	0	0
SW3	1	1	1	1	0	0	0	0	1	1	1	0	0	0	0	0
SW4	1	1	1	1	1	1	1	1	0	0	0	0	0	0	0	0

Fig. 2

The address is changed by setting a dip-switch positioned on the bottom of the drive. This switch must only be activated when the drive is turned off at the main isolator. Addresses from 1 to 16 may be selected, and Fig. 2 shows the different combinations.

When the MC12P is started, the whole network is initialised. The MC12P makes a global enquiry on the network and receives feedback from the individual drives, allowing it to record how many and which types of drives are available on the network.

When the drives have started their filling operations with their respective parameters, the MC12P will continuously scan the network to record when the drives have completed their tasks.

Finally all the counters are updated and the next job instruction (if any) is transmitted.

MC12P Reference Manual

2: INSTALLATION

2.1 Unpacking and inspection

Please check that all items ordered have been received and that no items were damaged during transport.

In case of any defects or omissions, please contact Flexicon A/S or your local supplier immediately.

When ordering spare parts for the MC12P, please state the serial number. The serial number is stamped on the label on the bottom of the MC12P.

ALWAYS REMEMBER that this machine must be earthed via its main cable.

2.2 Connections

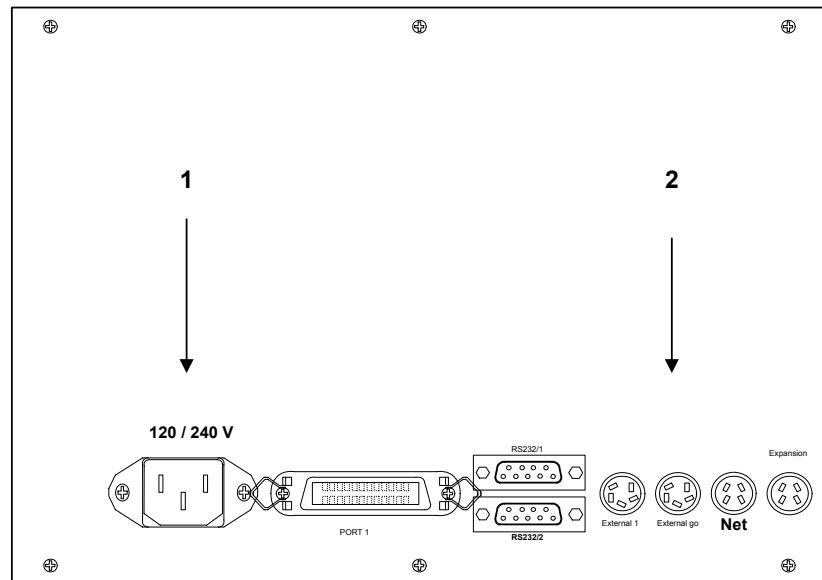

Fig. 2.2

The main cable supplied is connected to the main socket (1). The plug is connected to an earthed switch.

Using MC12P with stand-alone drive.

The communication cable (type 3) comes fitted with two 4-pin DIN plugs. One is connected to the “net” socket (2) of MC12P, and the other plug is connected to the “net 1” socket of the required filling station.

Using MC12P together with panel-mounted drive.

A communication cable is connected with a 4-pin DIN plug into the “Net” socket (2) of MC12P. The other end is mounted on pin 1 to pin 3 on the terminal on the panel-mounted drive, according to the guidelines in the manual for the drive.

MC12P is now ready to be switched on and to control the connected filling station.

Should it be required to connect more than one filling station to the same MC12P or to connect other equipment to it, the reference manual supplied should be consulted.

MC12P Reference Manual



3: CONTROL

3.1 Display

The display of the MC12P consists of 4 lines, each of 40 characters.
The display is lit from the back. This back lighting is switched off automatically, if the keypad has not been activated for 2 minutes. Activation of any key will switch on the back lighting again.

The blinking cursor of the display shows where a character will originate, if a key is activated.

ENTER FUNCTION No. :	P1
F 1: 100.00 ml.	F 2: 8.0 TUBE
F 3: 200 rpm	F 4: 10 ACC
F 5: 0 REV.	F 6: 1 fills

Fig. 3

The top line is the typing line and also the line, where the MC12P prompts the operator.

The penultimate character of the top line (P) indicates the operation mode of the MC12P: Parallel (P).

The last character of the top line (1) indicates the filling station connected.

The three lines below are status lines which always display the current operating parameters. These status lines can be scrolled by pressing the Up or Down Arrows of the keypad.









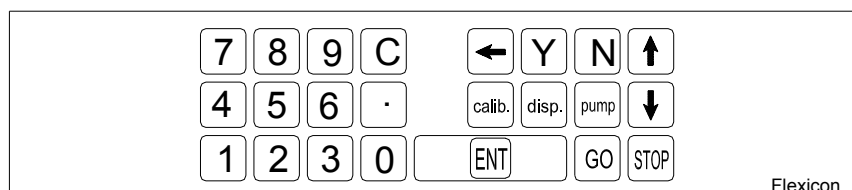



When operating the MC12P, it is VERY important to watch the top line constantly, as any current question or instruction will be written here.

MC12P Reference Manual

3.2 Keypad

The MC12P comes with a membrane-type keypad. The keypad is sealed and flat and can be cleaned with alcohol and other detergents.



    Numerical keys from 0 to 9 as well as
    point and C (delete) key.
   

 Delete character just in front of cursor.

 "Yes key" for Yes/No questions on display.

 "No key" for Yes/No questions on display

 Moves the status lines one line up.

 Moves the status lines one line down.

 Activates calibration.

 Activates filling.

 Activates continuous pumping

 Enter/return to enter the text typed in.

 Start button.

 Stop button

Figure 4

MC12P Reference Manual



4: PROGRAMMING

4.1 Starting the MC12P

In the following, the sign <> will mean that the indicated key must be activated. For instance, <ENT> means that ENTER must be pressed.

When the FMB200 is connected, the main switch on the left side of the control box can be turned on.

The display will show the following:

```
STANDBY
```

Fig. 5

Press the <GO> key, and the display will show the following:

```
* MC12 V1.1X (C) Flexicon 90-03 *  
PRESS GO TO CONTINUE.  
DRIVE No.: 1
```

Fig. 6

Verify that all connected drives are displayed with their respective numbers.

Then press <GO> once more, and the display will show the following:

```
ENTER FUNCTION NO. : 11  
F 1: 100.00 ml.      F 2: 8.0 TUBE  
F 3: 200 rpm        F 4: 10 ACC  
F 5: 0 REV.         F 6: 1 FILLS
```

Fig. 7

The values shown in the status lines will be the above or the latest values used.

4.2 Password Protection

This version of the MC12P is password protected. To be able to perform the following programming procedures it is necessary to be logged on as a supervisor (level 1).

This is done by selecting function 59, and enter the level 1 password.

Always remember to change the password level back to level 3 after programming.

Remember that merely switching MC12 off/on will NOT change any running parameters!

The MC12P is now ready to be programmed.

MC12P Reference Manual



4.3 Programming

The MC12P is function-controlled and each parameter has its own function number. The function is called by entering the number and pressing <ENT>. This can be done independently of the position of the cursor on the status lines.

The results is very fast and flexible programming where it is possible to gain direct access to the function to be changed.

4.4 Parameters

In the following a parameter will be the value of a single function, e.g. volume, velocity, number of fills etc.

4.5 Programs

In the following description a program will be a complete set of parameters which together will constitute the MC12P work instructions.

4.6 General information on the programming of the MC12P

The MC12P is equipped with a battery in the memory and will therefore always remember the programmed parameters, even if the main isolator is turned off.

This also means that when a function is called, the value last used will be suggested. The value may be overwritten or approved by pressing <ENT>.

The programming is done using functions. Each parameter has its own function number.

The programming is carried out by entering the function number followed by "ENT". This will make the required function appear in the prompt line of the display and show the current value or information of the function.

This value will automatically be overwritten when entering a new value. After being entered, the new value will be shown in the prompt line. The new value is entered into the computer by pressing "ENT".

The new value will be shown in the status lines at once.

Example:

If a volume of **8.5 ml** is required, the following should be entered:

<1>+<ENT>+<8>+<. >+<5>+<ENT>

The MC12P knows automatically which drive is connected. Consequently, values which are not valid for this drive will not be accepted. If an unacceptable value is entered, it will not be accepted, and a "beep" sound will be heard.

MC12P Reference Manual



5: DESCRIPTION OF FUNCTIONS

5.1 List of functions

1. Volume	31. Save program
2. Tube diameter	32. Load program
3. Velocity	33. Delete program
4. Acceleration/deceleration	34. Print programs
5. Reversing (back suction)	35. Free memory capacity
6. Batch size	40. Mode
7. Delay	41. Select filler
8. Completed fills	42. Set date
9. Specific gravity	43. Set time
10. Output rate	44. Display time and date
11. Accumulated volume	45. Display filler version
12. Maximum flow rate	46. Select language
16. Pumping direction (GD30I)	47. Printer set-up
17. Timer 1	48. RS232 set-up
18. Timer 2	49. Balance set-up
19. Timer 3	51. Filling needle set-up
20. Operator number	53. Drive deactivation
21. Batch number	58. Set passwords
22. Start Log	59. Change access level
23. Stop Log	60. Ext. Input mode
24. Print Log	70. Capacity format
25. Delete Log	71. Flow rate format
26. Log status	72. Volume format
29. Print parameters	80. Reset memory
	86. Complete memory reset

MC12P Reference Manual



5.2 Function 1, volume

1. Volume

Value		Option	Related Function(s)
Min	Max		
0.01	9999	ml. or gram	70

Function 1 informs the system of the volume to be filled.

The value is optional between ml and gram.

The entered value must be between 0.01 and 9999. If a value outside these limits is entered, the MC12 will correct the value to the nearest value within the limits and ask for acceptance via <ENT>.

When a volume is entered, the system will calculate the new parameter value which will then be used from the start of the next fill. At the same time, the status line will be updated.

For an individual fill only the parameter value for the drive in question will be changed.

For parallel or serial filling, the volume should be entered in drive 0 and the parameter value will be calculated for all connected drives.

F1 ENTER VOLUME: 15	I 1
F 1: 100.00 ml.	F 2: 8.0 TUBE
F 3: 200 rpm	F 4: 10 ACC
F 5: 0 REV.	F 6: 1 fills

Fig. 9

Press the keys

<1>+<ENT>+<1>+<5>+<ENT>

After changing the volume, recalibration should be carried out.

MC12P Reference Manual



5.3 Function 2, tube diameter

2. Tube diameter

Value: Inside diameter of the tube in mm.

Range:

A-Series		0.8		1.6	3.2	4.8	6.0	8.0		
B-Series	0.5	0.8	1.2	1.6	3.2	4.8	6.0	8.0		
PD22I / PD22					3.5		6.5	8.0	10.0	12.5

Enter the tube diameter used. The MC12 will only accept original Flexicon tube diameters. The diameters are specified in the manual for the drive and can be read on the tube gauge supplied with the drive.

As most of Flexicons drives are of the peristaltic type and work with tubes, the system must know the current tube diameter.

When programming a drive that does not use tubes as pumping element, this function will not be activated.

The tubes should be indicated by their inside diameter and from these data the MC12 will calculate how many revolutions the selected pump head should make in order to dispense the required volume.

If an unrecognised tube diameter is entered for the selected drive, the MC12 will not accept this diameter but will instead ask for a tube diameter from the original Flexicon range.

F2 ENTER TUBE : 4.8	I 1
F 1: 15.00 ml.	F 2: 3.2 TUBE
F 3: 300 rpm	F 4: 100 ACC
F 5: 0 REV.	F 6: 1 fills

Fig. 10

Press the keys

<2>+<ENT>+<4>+<. >+<8>+<ENT>

After changing the tube diameter, recalibration should be carried out.

MC12P Reference Manual



5.4 Function 3, velocity

3. Velocity

Value: Revolutions per minute (rpm).
Velocity range depends on tube size applied.
Range:

B-Series

Tube Sizes	Max. Velocity	Max. acceleration
0.5 - 0.8 – 1.2 – 1.6	600	200
3.2	500	150
4.8 - 6.0 – 8.0	400	100

The different drives have different ranges, and the range is stated in the drive manual.

If the drive connected is an “A” model from Flexicon, then:

A-Series

Tube Sizes	Max. Velocity	Max. acceleration
0.8 – 1.6 – 3.2 – 4.8 – 6.0 – 8.0	400	100

The fastest filling will be carried out at the highest velocity setting but the velocity should always be adjusted to suit the characteristics of the product and to reduce splashing or foaming.

If the velocity is changed during a fill, the fill will be completed using the original parameters and the new value will not be applied until the start of the next fill.

If the velocity is changed while using the unit as a pump, the drive will apply the new parameters immediately. The change will be carried out at the acceleration or deceleration entered in Function 4.

F3 ENTER SPEED :	350	I 1
F 1: 15.00 ml.	F 2: 4.8 TUBE	
F 3: 200 rpm	F 4: 10 ACC	
F 5: 0 REV.	F 6: 1 fills	

Fig. 11

Press the keys

<3>+<ENT>+<3>+<5>+<0>+ENT>

After changing the velocity, recalibration should be carried out.

MC12P Reference Manual



5.5 Function 4, acceleration/deceleration

4. Acceleration/deceleration

Value: An integral number.

The filling can start and stop more or less abruptly.

This function offers a choice of values between 1 and 200 dependent on the tube size and drive serie.

B-Series

Tube Sizes	Max. Velocity	Max. acceleration
0.5 - 0.8 – 1.2 – 1.6	600	200
3.2	500	150
4.8 - 6.0 – 8.0	400	100

The different drives have different ranges, and the range is stated in the drive manual.

If the drive connected is a A model from Flexicon, then:

A-Series

Tube Sizes	Max. Velocity	Max. acceleration
0.8 – 1.6 – 3.2 – 4.8 – 6.0 – 8.0	400	100

If a value outside the range between 1 and 100 is entered, the MC12 will automatically correct the value to the closest value allowed and the operator has to accept it by pressing the <ENT> key.

The function is used for optimising the filling according to the product and the shape of the bottle.

Function 4 affects pumping as well as filling and calibration.

If the value of the parameter is changed during a fill or calibration, the new value will not be applied until the start of the next fill or calibration.

F4 ENTER ACCELERATION:	35_ I1
F 1: 15.00 ml.	F 2: 4.8 TUBE
F 3: 350 rpm	F 4: 10 ACC
F 5: 0 REV.	F 6: 1 fills

Fig. 12

Press the keys

<4>+<ENT>+<3>+<5>+<ENT>

After changing the acceleration, recalibration should be carried out.

MC12P Reference Manual



5.6 Function 5, reversing

5. Reversing (back suction)

Value: An integral number.

When the filling stops, the filler can be asked to produce a small back suction to prevent dripping.

The back suction can be set at values between 0 and 10.

0 = no back suction

10 = maximum back suction.

The value has no relation to any other parameters and is solely a number of degrees of a rotor turn.

Consequently, the volume that is sucked back will depend on the tube diameter.

If a value outside the range between 0 and 10 is entered, the MC12 will automatically correct the value to the closest value allowed and the operator has to accept it by pressing the <ENT> key.

If the value of the parameter is changed during a fill, the new value will not be applied until the start of the next fill.

F5 ENTER REVERSE:	2_	1
F 1: 15.00 ml.	F 2: 8.0 TUBE	
F 3: 350 rpm	F 4: 35 ACC	
F 5: 0 REV.	F 6: 1 fills	

Fig. 13

Press the keys

<5>+<ENT>+<2>+<ENT>

After changing the reversing value, recalibration should be carried out.

MC12P Reference Manual



5.7 Function 6, batch size

6. Batch size

Value: Number

Enter the number of fills to be performed by the filler when started by the <GO> key, foot switch or via electrical signal.

Any number of fills between 1 and 65,000 can be selected.

When the filler is operating in an automatic system where the system itself starts the filler each time a bottle is in position, THE VALUE OF THIS FUNCTION MUST ALWAYS BE 1.

If a value outside the range between 1 and 65,000 is entered, the MC12 will automatically correct the value to the closest value allowed and the operator has to accept it by pressing the <ENT> key.

The value in Function 6 will only be active during filling, and after each fill the drive will wait for the time delay specified in Function 7 before the next fill is started.

When the system has completed the number of fills entered in Function 6, the system will stop and wait for a new <GO> command or a new starting signal, after which the system will once again carry out the number of fills entered in Function 6.

For filling in individual mode, the batch size should be entered for each single drive. For fills in parallel or serial mode, the batch size should be entered in drive 0.

F6 ENTER BATCH SIZE:	100_	11
F 1: 15.00 ml.	F 2: 4.8 TUBE	
F 3: 350 rpm	F 4: 35 ACC	
F 5: 2 REV.	F 6: 1 fills	

Fig. 14

Press the keys

<6>+<ENT>+<1>+<0>+<0>+<ENT>

Note: This function does not appear on display, if MC12P is integrated with Flexicon monoblocks, since the batch size on automatic vial processing system is set to 1.

MC12P Reference Manual



5.8 Function 7. delay

7. Delay

Value: Seconds.

If more than one fill is selected in Function 6, enter the required delay between the fills. The value of the delay can range between 0.0 and 25.0 seconds, with intervals of 0.1 second.

If a value outside the range between 0.0 and 25.0 is entered, the MC12 will automatically correct the value to the closest value allowed and the operator has to accept it by pressing the <ENT> key.

Function 7 is only active while filling is carried out and only if more than one fill has been entered in Function 6.

F7 ENTER DELAY:	1.2 SEC.	11
F 1: 15.00 ml.	F 2: 4.8 TUBE	
F 3: 350 rpm	F 4: 35 ACC	
F 5: 2 REV.	F 6: 100 fills	

Fig. 15

Press the keys

<7>+<ENT>+<1>+<. >+<2>+<ENT>

MC12P Reference Manual



5.9 Function 8, completed fills

8. Completed fills

Value: Number.

Nothing can be entered in this function as it only displays the number of fills completed since the latest reset of the function.

To reset this function, press the <C> key.

F8 FILLS: 0_	1
F 3: 350 rpm	F 4: 35 ACC
F 5: 2 REV.	F 6: 100 fills
F 7: 1.2 sec.	F 8: 0 fills

Fig. 16

Press the keys

<8>+<ENT>+<C>+<ENT>

5.10 Function 9, specific gravity

9. Specific gravity

The specific gravity of the product used can be entered here. Default value for this function is 1.0000 g/ml.

The MC12 uses this value to obtain the volume in F1, when volume mode is used. When using weight mode (function 72), specific gravity is automatically set to 1.0000 g/ml and is not alterable.

ENTER SPEC. GRAV.: 1.0000 g/ml	1
F 5: 2 REV.	F 6: 100 fills
F 7: 1.2 sec.	F 8: 0 fills
F 9: 1.0000 g/ml	F10: 0 fills/min

Fig. 17

Changing specific gravity should be followed by a calibration. (See section 7)

Example:

<9>+<ENT>

<0><.><9><8><5>+<ENT>

MC12P Reference Manual



5.11 Function 10, output rate

10. Output rate

Value: Number of fills per time unit.

Nothing can be entered in this function as it only displays the current output.

The function displays how many fills the system carries out per time unit. The time unit can be changed between hours and minutes in Function 70. See also information about Function 70.

The function operates as follows: The MC12 records the precise time between two fills via the built-in clock, and calculates the number of fillings per time unit.

The display is updated at the completion of each fill.

The function can be called up for viewing, but it cannot be reset and values cannot be entered in this function.

ENTER FUNCTION NO.:		I 1
F 5: 2 REV.	F 6: 100 fills	
F 7: 1.2 sec.	F 8: 5 fills	
F 9: 1.0000 g/ml	F10: 25 fills/min	

Fig. 18

After the first five fills using a PD12I, the display will show the above information.

5.12 Function 11, accumulated volume

Value: Litre

Nothing can be entered in this function as it only displays the total volume used since the last reset of function.

To reset this function, press the <C> key.

The value of this function is updated at the completion of each fill.

If the value of accumulated volume is less than 1,000 litres, it will be displayed with 3 decimals. If the value is equal to or more than 1,000 litres, it will be displayed with one decimal.

F11 :ACC.VOLUME:0.000I		I 1
F 5: 2 REV.	F 6: 100 fills	
F 7: 1.2 sec.	F 8: 0 fills	
F 9: 1.0000 g/ml	F10: 0 fills/min	

Fig. 19

MC12P Reference Manual



5.13 Function 12, maximum flow

Value: Volume per time unit.

Nothing can be entered in this function as it only displays the current maximum flow.

The read-out is based on the flow created when the rotor runs at the required velocity.

The function reads out how much liquid the system pumps through the tubes per time unit. This unit can be changed in Function 71. See the information about Function 71.

Nothing can be entered in this function, and the read-out will be updated immediately after changing the value in Function 2 or Function 3.

F12 : FLOW :	I 1
F 7: 1.2 sec.	F 8: 0 fills
F 9: 1.0000 g/ml	F10: 0 fills/min
F11: 0.0001 l	F12 : 0 ml/min

Fig. 20

F12 will not be visible in the status display if connected to a drive that can change direction e.g. GD30I

5.14 Function 16, pumping direction

16. Pumping direction

Value: Clockwise or counter-clockwise.

As not all drives can work with more than one pumping direction, this function will only be active when connected to a drive with that option e.g. GD30I.

F16 DIRECTION (1/2):	1_	I 1
F 7: 1.2 sec.	F 8: 5 fills	
F 9: 1.0000 g/ml	F10: 25 fills/min.	
F11: 1728.39 ml/min	F16: NORMAL DIR.	

Fig. 21

1 = CLOCKWISE ROTATION

2 = COUNTER-CLOCKWISE ROTATION

= product from top of pump

= product from side of pump

Thick creams require a feed hopper mounted on top of the pump and consequently, pumping direction 1 is used.

For products which flow more freely and can be drawn up against gravity e.g. shampoo, the suction tube is mounted on the side of the pump and consequently, pumping direction 2 is used.

MC12P Reference Manual



5.15 Function 17, timer 1

17. Timer 1

Value: Seconds.

A time interval can be set between a starting signal and the time the drive actually starts. The starting signal can be either the <GO> key or an external starting signal. The range is between 0.0 and 25.0 seconds at intervals of 0.1 second.

If a value outside the range between 0.0 and 25.0 is entered, the MC12 will automatically correct the value to the closest value allowed and the operator has to accept it by pressing the <ENT> key.

For instance if 1.25 sec. have been entered, the MC12 will round the value to 1.2 sec.

F17 TIMER 1: 1.2_ sec.	
F 9: 1.0000 g/ml	F10: 25 fills/min.
F11: 1728.39 l.	F12: 15 ml/min
F17: 0.0 sec.	F18: 0.0 sec.

Fig. 22

Press the keys

<1>+<7>+<ENT>+<1>+<. >+<2>+<ENT>

5.16 Function 18, timer 2

18. Timer 2

Value: Seconds.

A delay can be set between the starting signal and the time the drive actually starts. The starting signal can be either the <GO> key or an external starting signal.

The range is between 0.0 and 25.0 seconds at intervals of 0.1 second.

For the duration of the delay specified in Timer 2, the status signals of the two external ports will be active and continue to be active during the filling of the drive.

If a value outside the range 0.0 to 25.0 is entered, the MC12 will automatically correct the value to the closest value allowed and prompt the operator to accept it by pressing <ENT>.

For instance if 1.25 sec. have been entered, the MC12 will round the value to 1.2 sec.

F18 TIMER 2: 0.3_ sec.		I 1
F11: 1728.39 ml.min.	F12: 100 ml/min	
F17: 0.2 sec.	F18: 0.0 sec.	
F19: 0.0 sec.		

Fig. 23

<1>+<8>+<ENT>+<0>+<. >+<3>+<ENT>

MC12P Reference Manual



5.17 Function 19, timer 3

19. Timer 3

Value: Seconds.

A time interval can be set where the status signal says that the drive is operating AFTER it actually stopped.

The range is between 0.0 and 25.0 seconds.

For the duration of the delay specified in Timer 3, the status signals of the two external ports will be active after the completion of the filling of the drive.

If a value outside the range between 0.0 and 25.0 is entered, the MC12 will automatically correct the value to the closest value allowed and the operator has to accept it by pressing the <ENT> key.

For instance if 1.25 sec. have been entered, the MC12 will round the value to 1.2 sec..

F19 TIMER 3: 0.1_ sec.	I 1
F11: 1728.39 ml./min.	F12: 100 ml/min
F17: 0.2 sec.	F18: 0.3 sec.
F19: 0.0 sec.	

Fig. 24

<1>+<9>+<ENT>+<0>+<. >+<1>+<ENT>

MC12P Reference Manual



5.18 Function 20, operator number

20. Operator number

An operator number can be entered in Function 20.

The maximum number of digits in an operator number is 12. This means that an operator number is an integral number between 0 and 999999999999.

With this function it is possible to inform the system which operator is in charge of the current production. The operator number entered will always appear on print-outs of the log (F24) and the operating parameters (F29).

```
F20 OPERATOR: 1256_          | 1
F17: 0.2 sec                F18: 0.3 sec
F19: 0.1 sec.
F20: OPERATOR
```

Fig. 25

<2>+<0>+<ENT>+<1>+<2>+<5>+<6>+<ENT>

5.19 Function 21, batch number

21. Batch number

A batch number can be entered in this function.

The maximum number of digits in a batch number is 12. This means that a batch number is an integral number between 0 and 999999999999.

With this function the operator can inform the system of the batch or production number under which the current production is recorded. The batch number entered will always be shown on print-outs of the log (F24) and print-outs of the operating parameters (F29).

```
F21 BATCH NO.: 97052183_    | 1
F19: 0.1 sec.
F20: 1256 OPERATOR
F21: BATCH NO.
```

Fig. 26

<2>+<1>+<ENT>+<9>+<3>+<0>+<6>+<2>+<1>+<8>+<3>+<ENT>

MC12P Reference Manual



5.20 Function 22, start log

22. Start log

By using this function automatic logging in the internal memory can be started. When the log is started all parameters as well as changes and calibrations will be entered and may subsequently be printed out for full production documentation.

```
F22 START LOG (Y/N): _ | 1
F20: 1256 OPERATOR
F21: 97062183 BATCH NO
F22: START LOG          F23: STOP LOG
```

Fig. 27

Start log by entering

<2>+<2>+<ENT>

When the function is started, the MC12 will ask for confirmation that the log start should go ahead by prompting the user to enter (Y) for 'yes' and (N) for 'no'. If <N> for 'no' is pressed, the MC12 will exit the function.

If <Y> for 'yes' is pressed, the following question will appear:

```
F22 DEL OLD LOG (Y/N): _ | 1
F20: 1256 OPERATOR
F21: 97062183 BATCH NO
F22: START LOG          F23: STOP LOG
```

Fig. 28

If <N> for 'no' is pressed, all existing information will be saved in the memory and the new data will be stored after the original data. Please note that the log capacity is limited; therefore an old log should always be deleted WHEN it has been printed out.

If <Y> for yes is pressed, all old data in the memory will be deleted before the log is started.

```
ENTER FUNCTION NO.: _ | L | 1
F20: 1256 OPERATOR
F21: 97062183 BATCH NO
F22: START LOG          F23: STOP LOG
```

Fig. 29

As long as the log is active, an L will be visible at the right hand side of the prompt line.

MC12P Reference Manual



5.21 Function 23, stop log

23. Stop Log

This function stops the automatic logging of production data (Log).

When a production has been completed and the log has been active, the log should be stopped before print-out.

If the log is active, an L will be visible at the right hand side of the prompt line.

```
F22 STOP LOG (Y/N): _ | 1
F20: 1256 OPERATOR
F21: 99062183 BATCH NO
F22: START LOG          F23: STOP LOG
```

Fig. 30

Stop log by entering

<2>+<3>+<ENT>

When the function is entered, the MC12 will ask for confirmation that the log should stop by prompting the user to enter (Y) for 'yes' and a (N) for 'no'. If <N> for 'no' is pressed, the MC12 will exit the function.

If <Y> for yes is pressed, the logging of data for the memory will be stopped.

5.22 Function 24, print log

24. Print Log

If a printer is connected, this function will start the printing of the log.

When the function is started, the MC12 will ask for confirmation that the log should be printed by prompting the user to enter (Y) for 'yes' and (N) for 'no'. If <N> for 'no' is pressed, the MC12 will exit the function.

```
F22 PRINT LOG (Y/N): _ | 1
F20: 1256 OPERATOR
F21: 97062183 BATCH NO
F22: START LOG          F23: STOP LOG
```

Fig. 31

If <Y> for 'yes' is pressed, the MC12 will prompt for Y/N decision regarding continuous log.

MC12P Reference Manual



F24:PRINT CONTINUOUSLY(Y/N)	1
F20:	
F21:	
F22:	F23: STOP LOG

Fig. 32

If <Y> for 'yes' is pressed, the incoming log will be printed out continuously. These log-data will automatically be erased. This function can be used if MC12 is used together with a scales and if there is a risk of overloading the log by generating many data.

If <N> is pressed, the complete log will be printed out and printer will stop at the end of log.

The printing is carried out as background printing, i.e. the MC12 can be operated while printing takes place.

Example of print-out of log:

MC12P Reference Manual



```

* MC12 V1.0X *

01/01/06 14:23 START LOG
                    OPERAT.          1256
                    BATCH NO.        97062183
                    WRK. MODE
INDIVIDUAL
                    16
01/01/06 14:23 DRIVE NO.          PD 12I
                    TYPE              50.000
                    VOLUME (ml)       6.0
                    TUBE (mm)         125
                    VELOCITY (rpm)    10
                    ACCELERATION      0
                    REVERSE           1
                    BATCH SIZE        1.0
                    DELAY (sec)       1.000
                    SP. GRV.(g/ml)    0
                    FILLS              0.0000
                    ACC.VOL. (l)      0.0
                    TIMER 1 (sec)     0.0
                    TIMER 2 (sec)     0.0
                    TIMER 3 (sec)     0.0

01/01/06 14:25 RECAL. FROM BALANCE  10
                    FILL NO.          50.120
                    VOLUME (ml)
                    .....

01/01/06 14:46 STOP LOG            10
                    FILLS              3.180
                    ACC.VOL. (l)       10
                    NO. OF RECALIB.    50.165
                    MEAN VOL (ml)     0.069
                    STD. DEV. (ml)

```

When the log is stopped by using function 23, the MC12 prints out the number of fillings and accumulated volume recalibrations from balance as well as related average and standard deviation for recalibration values.

If the MC12 is used with a balance (see function 49), the registered data from balance are printed out as a part of log and the number.

Please be aware that specific gravity is printed only if the volume format is set to ml.

MC12P Reference Manual



5.23 Function 25, delete log

25. Delete Log

Deletes the log memory.

This function deletes all data stored in the log. It is recommended that the log be deleted immediately after the log has been printed via Function 24.

F25 DELETE LOG (Y/N):	—	1
F21: 97062183 BATCH N \bar{O}		
F22: START LOG		F23: STOP LOG
F24: PRINT LOG		F25: DELETE LOG

Fig. 33

When the function is called, the system will ask if the log is to be deleted.

If <Y> for 'yes' is pressed, all data in the log will be deleted.

If <N> for 'no' is pressed, the system will exit the function without deleting the data in memory.

5.24 Function 26, log status

26. Log Status

This function displays the number of used and free bytes in the log memory.

5,000 bytes are reserved in the memory for logging data and Function 26 enables the user to see how much capacity is left in this memory.

F26 FREE: 4620 USED:	380	—	1
F22: START LOG		F23: STOP LOG	
F24: PRINT LOG		F25: DELETE LOG	
F26: LOG DATA		F29: PRINT PARAM	

Fig. 34

As the log is being progressively filled, the figure under FREE will become lower and the figure under USED will become higher.

If the log (memory) is full and data is still being logged, these last data will be lost.

MC12P Reference Manual



5.25 Function 29, print parameters

29. Print parameters

This function prints the current parameters via the connected printer. The print-out is for the current drive or all the current drives.

When the function is called, the system will ask the following questions:

F29 PRINT ACTUAL DRIVE (Y/N): _	1
F22: START LOG	F23: STOP LOG
F24: PRINT LOG	F25: DELETE LOG
F26: LOG DATA	F29: PRINT PARAM

Fig. 35

For print-out of the current drive only, press <Y>.

For print-out of all connected drives, press <N>.

F29 START PRINT (Y/N) _	1
F22: START LOG	F23: STOP LOG
F24: PRINT LOG	F25: DELETE LOG
F26: LOG DATA	F29: PRINT PARAM

Fig. 36

The printing can now be started by pressing <Y>, or the function can be left by pressing <N>. In both parallel and serial mode, the system prints out all parameters for drive 0 (see also function 40). When operating in serial mode the size of tube for all drives is printed.

MC12P Reference Manual



Example of print-out of current parameters:

* MC12 V1.0X *	
DATE	01/06/15
TIME	15:43:07
OPERATOR	1256
BATCH NUMBER	97051583
WORKING MODE	INDIVIDUAL
DRIVE NO.	1
DRIVE TYPE	PD 12I
VOLUME (ml)	15.00
TUBE (mm)	4.8
SPEED (rpm)	350
ACCELERATION	35
REVERSE	2
BATCH SIZE	100
DELAY (sec)	1.2
NUMBER OF FILLS	100
ACCUMULATED VOLUME (l)	0.000
TIMER 1 (sec)	0.2
TIMER 2 (sec)	0.3
TIMER 3 (sec)	0.1

If parameters for all drives are printed, the last part of the print-out will be repeated for all connected drives, but with the respective parameters.

MC12P Reference Manual



5.26 Function 31, save program

31. Save program

Saves a complete set of parameters as a program.

It is possible to save up to 100 sets of parameters in the memory, i.e. one drive will have 100 programs available, and with two drives, each will have 50 programs available.

If a particular set of parameters is used frequently, it is a good idea to store the settings in order to allow their easy retrieval as a complete filling program. This also ensures that exactly the same parameters are used each time, Reducing the risk of programming errors.

A stored program contains the following function parameters:

The individual drives: F1 - F2 - F3 - F4 - F5 - F6 - F7 - F9 - F17 - F18 - F19 – F40 - F41 - 51- F53 and the last calibration value.

It is important that all parameters are entered and that these parameters are checked before saving the program saved via Function 31.

F31 SAVE PROGRAM NO. F31: 1_	1
SAVE PROGRAM	F32: LOAD PROGRAM
F33: DELETE PROGRAM	F34: PRINT PROGRAM
F35: PROGRAM DATA	

Fig. 37

The system will always suggest the first available number in a range between 1 and 100.

If this number is to be accepted as the program number, press <ENT>, and all parameters will be saved under this program number.

If another number is required, enter the number chosen, and if this number is free, the program is saved by pressing <ENT>.

If the number is occupied by a program already saved, the following display will appear:

F31 OVERWRITE PGM. (Y/N):	̄	1
F31: SAVE PROGRAM	F32: LOAD PROGRAM	
F33: DELETE PROGRAM	F34: PRINT PROGRAM	
F35: PROGRAM DATA		

Fig. 38

If <Y> is pressed, the old program is deleted and the new program is saved with this number.

If <N> is pressed, the system will go back to the position from which a new program number can be selected.

Select a new program number and press <ENT> to confirm this new number.

MC12P Reference Manual



The old program saved under the number originally suggested will be kept and the program will be saved under the new number.

If program number 0 is selected, the function is left without saving the program.

5.27 Function 32, load program

32. Load program

Loads a program already saved and overwrites the current parameters with the values of the program.

When pressing <3>+<2>+<ENT> the following questions will appear:

F32 LOAD PROGRAM NO.:	1
F31: SAVE PROGRAM	F32: LOAD PROGRAM
F33: DELETE PROGRAM	F34: PRINT PROGRAM
F35: PROGRAM DATA	

Fig. 39

By pressing the required program number followed by <ENT>, the operating parameters saved under the specified program number will be entered as the current parameters under the respective functions.

At the same time, the following functions will be reset: F8 - F9 - F11 - F20 - F21.

If a calibration of the specific tube has been carried out, these parameters will also be loaded.

If program number 0 is selected, the function is left without loading a program and the system will keep the current values.

MC12P Reference Manual



5.28 Function 33, delete program

33. Delete program

This function will delete a specific program.

If a complete program is to be deleted, this can be done by overwriting it via Function 31, or the program can be deleted via Function 33.

When entering <3>+<3>+<ENT> the system will ask for the program number to be deleted.

F33 DELETE PROGRAM NO.:	0_	1 1
F31: SAVE PROGRAM		F32: LOAD PROGRAM
F33: DELETE PROGRAM		F34: PRINT PROGRAM
F35: PROGRAM DATA		

Fig. 40

When pressing the required program number followed by <ENT> the specified program will be deleted.

If a number is entered under which no program is saved, the system will not accept it and the number must be corrected, or the function can be left by pressing <0>+<ENT>.

MC12P Reference Manual



5.29 Function 34, print programs

34. Print programs

This function prints the individual parameters in all the programs stored in the memory.

When pressing <3>+<4>+<ENT> the system will ask the following:

F34 PRINT PROGRAMS	(Y/N):	_	I 1
F31: SAVE PROGRAM	F32: LOAD PROGRAM		
F33: DELETE PROGRAM	F34: PRINT PROGRAM		
F35: PROGRAM DATA			

Fig. 41

When pressing <N> the system will leave the function, without carrying out the function.
When pressing <Y> the system will start printing the parameters in all programs saved.

Example of program print-out:

* MC12 V1.0X *	
DATE	01/01/07
TIME	14:08:45
PROGRAM NO.	1
DRIVE NO.	16
WORKING MODE	INDIVIDUAL
VOLUME (ml)	70.00
TUBE (mm)	8.0
SPEED (rpm)	300
ACCELERATION	60
REVERSE	0
BATCH SIZE	1
DELAY (sec)	1.0
TIMER 1 (sec)	0.0
TIMER 2 (sec)	0.0
TIMER 3 (sec)	0.0
PROGRAM NO.	2
DRIVE NO.	1
-----ETC-----	

MC12P Reference Manual



5.30 Function 35, free memory capacity

35. Free memory capacity

This function shows how many used and free programs are left in the memory.

When pressing <3>+<5>+<ENT> the system will show how many programs are saved as well as the free memory capacity.

F35 FREE: 98 USED: 2	1
F31: SAVE PROGRAM	F32: LOAD PROGRAM
F33: DELETE PROGRAM	F34: PRINT PROGRAM
F35: PROGRAM DATA	

Fig. 42

FREE indicates the number of programs (complete sets of operating parameters) which can still be saved.

USED indicates the number of programs (complete sets of operating parameters) saved.

MC12P

Reference Manual



5.31 Function 40, mode

40. Mode

Value: An integral number.

If more than one drive is connected, the MC12 can operate in three different modes:

- 1 - individual
- 2 - parallel
- 3 - serial

The mode will always be shown by the letter I, P or S in the top right hand corner of the display, in front of the current drive number. I1, for example, means that the mode is individual and the current drive address is 1.

I = Individual
P = Parallel
S = Serial

I - Individual (1)

Individual filling means that each drive has its own operating parameters and that fills, calibration and pumping will not be synchronised with any other connected drives. In theory, this means that the MC12 can control up to 16 drives concurrently.

The parameters are programmed under the individual drive addresses which are selected via Function 41. In practice, however, it is difficult to run several individual applications simultaneously, as the drive has to be selected first via Function 41 for starting, stopping and calibrating.

P - Parallel (2)

Parallel filling is used in a multi-head filling system in which a number of bottles are changed in each cycle and filled at the same time. This gives a very high capacity. The number of drives and the number of bottles changed at each cycle should be identical.

If more drives are connected to the MC12, they can, if they are of the same type, work synchronously with the same set of parameters. In parallel mode, only parameters in drive 0 will be used i.e. all drives use same volume, tube size, acc, etc. All drives are started simultaneously regardless of where they are started from. These parameters then apply for all drives.

ENTER FUNCTION NO.:	P 0
F 1: 10.00 ml.	F 2: 3.2 TUBE
F 3: 400 rpm	F 4: 50 ACC.
F 5: 0 REV.	F 6: 1 fills

Fig. 43

Calibration must be carried out for the individual drives, see the chapter on calibration for further details.

The system will not report that the filling has been completed until all connected drives have completed their respective fills. After this, Functions 8, 10 and 11 for drive 0 will be updated by the total of all connected drives.

MC12P Reference Manual



S - Serial (3)

Serial filling is used to boost the overall capacity in a semi or fully automated system by using each drive to fill part of the total volume.

Similar to parallel filling, drive 0 is used for programming, with the exception of Function 2 for tube diameter.

For the programming of tube diameter the individual drive is selected via Function 41 and the tube diameter is entered under Function 2. In this way, the last drive may for instance fill a smaller part of the total volume than the other drives in the system. This is done by applying a smaller tube in the last drive.

When all drives have been programmed, the MC12 will automatically calculate which part of the total volume the individual drives should fill, so that they are completed simultaneously. This gives the best capacity.

ENTER FUNCTION NO.:	S 0
F 1: 10.00 ml.	
F 3: 400 rpm	F 4: 50 ACC.
F 5: 0 REV.	F 6: 1 fills

Fig. 44

Calibration is also carried out in drive 0, as the system perceives the whole system as one single drive.

Functions 8 and 10 will be calculated on the basis of completed fills from the last drive and Function 11 will be calculated on the basis of all drives.

MC12P Reference Manual



5.32 Function 41, select filler

41. Select filler

Function 41 selects the drive to be programmed and shown on the display. The current drive number is always shown in the top right hand corner of the display. If Function 41 is selected, the following display will appear:

<4>+<1>+<ENT>

F41 ENTER DRIVE NO.:	1_	I 1
F40: 1 MODE	F41: SELECT DRIVE	
F42: CHANGE DATE	F43: CHANGE TIME	
F44: VIEW WATCH	F45: VIEW VERSION	

Fig. 45

The drive number required for the new drive can now be entered, followed by <ENT>. The system will then show the new current drive in the display indicating the new number in the top right hand corner. If a drive number is entered which is not connected, the system will correct the number to the lowest number representing a connected drive.

Drive 0

Drive 0 does not exist physically. Drive 0 is used as the current drive when the system works in the parallel or serial mode.

Drive 0 in individual mode

Drive 0 is not used in this mode as all drives work with different parameters and applications.

Drive 0 in parallel mode

The following parameters are identical for all drives in the parallel mode and they are consequently programmed in drive 0:

F 1: Volume	F 2: Tube diameter
F 3: Velocity	F 4: Acceleration/deceleration
F 5: Reversing	F 6: Batch size
F 7: Delay	F17: Timer 1
F18: Timer 2	F19: Timer 3

When selecting drive 0 after having selected parallel (2) mode in Function 41, the display could look as follows:

ENTER FUNCTION NO.:	P 0
F 1: 10.00 ml.	F 2: 3.2 TUBE
F 3: 400 rpm	F 4: 50 ACC.
F 5: 0 REV.	F 6: 1 fills

Fig. 46

MC12P Reference Manual



Calibration and recalibration should not be carried out under drive 0 but under the respective drive numbers. See the chapter on calibration for further details.

Drive 0 in serial mode

The following parameters are system parameters and should therefore be entered under drive 0:

F 1: Volume	F 3: Velocity
F 4: Acceleration/deceleration	F 5: Reversing
F 6: Batch size	F 7: Delay
F17: Timer 1	F18: Timer 2
F19: Timer 3	
Calibration	Recalibration

Function 2, tube diameter, is entered under the respective drives by entering F41 and drive number. In this way the last drive may carry out only a small part of the total fill, providing a small tube is selected for this drive.

When selecting drive 0 after having selected serial mode (3) in Function 41, the display could look as follows:

ENTER FUNCTION NO.:	S 0
F 1: 10.00 ml.	
F 3: 400 rpm	F 4: 50 ACC.
F 5: 0 REV.	F 6: 1 fills

Fig. 47

As can be seen from the above, tube diameter cannot be entered.

5.33 Function 42, set date

42. Set date

The MC12 has a built-in electronic clock and calendar. With Function 42 the date can be set in the following format:

YY/MM/DD

YY = the year from 00 - 99
MM = the month from 01 - 12
DD = the day of the month from 01 - 31

The date is entered by first entering the year, then the month and finally the day.

F42 ENTER DATE:	01/07/15_	I 1
F40: 1 MODE	F41: SELECT DRIVE	
F42: CHANGE DATE	F43: CHANGE TIME	
F44: VIEW WATCH	F45: VIEW VERSION	

MC12P Reference Manual



Fig. 48

Example:

<4>+<2>+<ENT>+<9>+<7>+<ENT>+<0>+<7>+ENT>+<1>+<5>

By pressing <ENT> the new date will be stored in the system.

The system calculates automatically the days of the month. If the date 97/04/31 is entered by mistake, the system will correct the date when the clock changes from 23/59/59 to 00/00/00. The system does NOT take Summer Time into account.

MC12P Reference Manual



5.34 Function 43, set time

43. Set time

The MC12 has a built-in electronic clock and calendar. With Function 43 the time can be set in the following format.

HH/MM/SS

HH = hours from 00 - 23

MM = minutes from 00 - 59

SS = seconds from 00 - 59

The time is entered by first entering hours, then minutes and finally seconds.

F43 ENTER TIME:	16:58:46_	1
F40: 1 MODE	F41: SELECT DRIVE	
F42: CHANGE DATE	F43: CHANGE TIME	
F44: VIEW WATCH	F45: VIEW VERSION	

Fig. 49

Example:

<4>+<3>+<ENT>+<1>+<6>+<ENT>+<5>+<8>+ENT>+<4>+<6>

By pressing <ENT>, the new time will be stored in the system.

If any other value is entered, the system will correct the number to the closest value allowed and the operator has to accept it by pressing the <ENT> key.

5.35 Function 44, display time and date

44. Display time and date

Will display time and date on display.

Example:

<4><4><ENT>

F44 WATCH: 97/07/15	17:01:05	1
F40: 1 MODE	F41: SELECT DRIVE	
F42: CHANGE DATE	F43: CHANGE TIME	
F44: VIEW WATCH	F45: VIEW VERSION	

Fig. 50

Date and time in the prompt line will be updated continuously as long as it is displayed. New values can be entered via Functions 42 and 43 only and not via this function.

MC12P Reference Manual



5.36 Function 45, display drive version

45. Display drive version

This function displays the type and version of the currently connected drive.

F45 DRIVE: PD 12I V1.2 _	1
F40: 1 MODE	F41: SELECT DRIVE
F42: CHANGE DATE	F43: CHANGE TIME
F44: VIEW WATCH	F45: VIEW VERSION

Fig. 51

<4>+<5>+<ENT>

Type and version will remain visible until <ENT> is entered.

5.37 Function 46, select language

46. Select language

Value: An integral number.

This version offers a choice of four languages.

- 1 - Danish
- 2 - English
- 3 - German
- 4 - French

The languages will be active on the display and on the print-outs.

Examples of displays in English.

ENTER FUNCTION NO.: _	1
F40: 1 MODE	F41: SELECT DRIVE
F42: CHANGE DATE	F43: CHANGE TIME
F44: VIEW WATCH	F45: VIEW VERSION

Examples of displays in German.

FUNKTIONS-NR. EINGEBEN: _	1
F40: 1 FUELLART	F41: DOSIERPUMPE-NR.
F42: DATUM AENDERN	F43: UHRZEIT AENDERN
F44: UHRZEIT KONTR	F45: VERSION KONTROL

Fig. 52

MC12P Reference Manual



5.38 Function 47, printer set-up

47. Printer set-up

This function tells the system how to transmit data to a connected printer and which port to use for the transmission.

<4>+<7>+<ENT>

F47 ENTER PORT NO.:	1_	1
F44: VIEW WATCH	F45: VIEW VERSION	
F46: 2 LANGUAGE	F47: PRINTER-SETUP	
F48: RS232-SETUP	F49: BALANCE SETUP	

Fig. 53

First choose the port number:

Here the port number is entered followed by <ENT>.

0 = Disconnecting printer port

1 = RS-232/1

2 = RS-232/2

Now the system asks for the baud rate:

F47 ENTER BAUDRATE:	2400_	1
F44: VIEW WATCH	F45: VIEW VERSION	
F46: 2 LANGUAGE	F47: PRINTER-SETUP	
F48: RS232-SETUP	F49: BALANCE SETUP	

Fig. 54

The system will suggest the value already stored. This value can be either approved by <ENT> or it can be overwritten by the baud rate required according to the following table:

75	110	134	150	300	600	1200	1800	2000	2400	4800
	9600									

The system will only accept a value from the above table.

MC12P Reference Manual



When the baud rate has been entered in the system, the system will prompt the operator to enter a control word:

F47 ENTER CONTROLWORD	7_	1
F44: VIEW WATCH		F45: VIEW VERSION
F46: 2 LANGUAGE		F47: PRINTER-SETUP
F48: RS232-SETUP		F49: BALANCE SETUP

Fig. 55

The control word, which is an integral number from 1 to 12 will inform the system of the format in which data is to be transmitted to the printer. The format is chosen from the following table:

1 =	7 data bits	1 stop bit	no parity
2 =	7 data bits	1 stop bit	even parity
3 =	7 data bits	1 stop bit	odd parity
4 =	7 data bits	2 stop bits	no parity
5 =	7 data bits	2 stop bits	even parity
6 =	7 data bits	2 stop bits	odd parity
7 =	8 data bits	1 stop bit	no parity
8 =	8 data bits	1 stop bit	even parity
9 =	8 data bits	1 stop bit	odd parity
10 =	8 data bits	2 stop bits	no parity
11 =	8 data bits	2 stop bits	even parity
12 =	8 data bits	2 stop bits	odd parity

It is not possible to set the system to transmit at any other rates or formats.

Default set-up for CITIZEN printer model: iDP562-R5L

2400 Baudrate
Control Word 7 (8 bit - 1 stop bit - no parity)
US Character set.

MC12P Reference Manual



5.39 Function 48, RS232 set-up

48. RS232 set-up

This function is not active as it is only used for special requirements.

5.40 Function 49, Balance set-up

49. Balance set-up

A balance can be used together with MC12 to perform dynamic recalibration when filling. The balance set-up is controlled by use of function 49:

<4>+<9>+<ENT>

The display now shows the line:

F49 BALANCE:MODE(1)/SETUP(2):0_	1
F44: VIEW WATCH	F45: VIEW VERSION
F46: 2 LANGUAGE	F47: PRINTER-SETUP
F48: RS232-SETUP	F49: BALANCE SETUP

Fig. 56

Select either 0 to return to the main menu, 1 for choose of mode for balance operation, or 2 for set-up of balance interface.

Set-up (2).

If set-up of interface is selected by entering:

<2> + <ENT>

the command line displays:

F49 METTLER (1)/SARTORIUS (2): 1_	1
F44: VIEW WATCH	F45: VIEW VERSION
F46: 2 LANGUAGE	F47: PRINTER-SETUP
F48: RS232-SETUP	F49: BALANCE SETUP

Fig. 57

According to the connected balance, select either Mettler by pressing <1>+<ENT> or Sartorius by pressing <2>+<ENT>. After entering the manufacturer of the balance, the MC12 asks which RS232 port that is used as scale interface by displaying:

MC12P Reference Manual



F49 ENTER PORT NO.: 2_	I 1
F44: VIEW WATCH	F45: VIEW VERSION
F46: 2 LANGUAGE	F47: PRINTER-SETUP
F48: RS232-SETUP	F49: BALANCE SETUP

Fig. 58

Port no. 2 (RS-232/2 on the rear panel of the MC12) is default, and the MC12 suggests this port. Press <ENT> for approval. If you want to use port no. 1 then press <1>+<ENT> instead. NB: to use port 1 you must first disconnect the printer set-up from port 1 by either disconnecting the printer set-up by selecting port number 0 in function 47 or by selecting port number 2 as printer port in function 47.

MC12 has the following default set-up values for SARTORIUS® and METTLER®.

	METTLER®	SARTORIUS®
Baud Rate	2400	1200
Data Bit	7	7
Stop Bit	1	1
Parity	Even	Odd
Handshake	OFF	ON

Mode (1).

Mode set-up is selected by re-entering function 49:

<4>+<9>+<ENT>

and then pressing:

<1>+<ENT>

the display shows:

F49: DYNAMIC RECAL.(1)/FILL(2): 0_	I 1
F44: VIEW WATCH	F45: VIEW VERSION
F46: 2 LANGUAGE	F47: PRINTER-SETUP
F48: RS232-SETUP	F49: BALANCE SETUP

Fig. 59

Here the choices are (by pressing the number followed by ENT):
 0: Disconnects the balance set-up
 1: Dynamic recalibration
 2: Filling (or dispensing) interactively with balance

MC12P Reference Manual



Dynamic recalibration.

If dynamic recalibration has been selected (**Individual mode**), the display line will show:

RECALIB. INTERVAL (%): 10_	I 1
F44: VIEW WATCH	F45: VIEW VERSION
F46: 2 LANGUAGE	F47: PRINTER-SETUP
F48: RS232-SETUP	F49: BALANCE SETUP

Fig. 60

Here the recalibration interval (see fig.81) is entered. When a weight that lies within the chosen percentage interval around the volume set in function 1, this weight registration is used to recalibrate the machine. Weights registered outside the interval will be interpreted as e.g. bottle tarring, and will therefore not be used as recalibration values.

Select a recalibration interval and press <ENT>. The MC12 will now ask for a filling accuracy percentage by showing:

FILLING ACCURACY (%):1.0_	I 1
F44: VIEW WATCH	F45: VIEW VERSION
F46: 2 LANGUAGE	F47: PRINTER-SETUP
F48: RS232-SETUP	F49: BALANCE SETUP

Fig. 61

This feature is used only to advise the operator if a registered weight lies within the production requirements to the volume accuracy. When a weight is registered a short beep in a higher frequency indicates a sample inside the production tolerance. A longer beep in a lower frequency indicates a sample outside the production tolerance. Furthermore, if a Mettler balance is used the text "REJECT" will be shown on the balance display. Press <ENT> to confirm the accuracy.

The dynamic recalibration from balance is now ready for operation. To use it simply put a bottle on the balance and tare. When the bottle has been filled, put it back on the balance. When the MC12 gives a high tone beep, the weight has been registered and used for recalibration. *For more information on beeps please refer to fig. 81*

When the MC12 is set for dynamic recalibration, this is indicated by a "D" in the upper right corner of the display.

MC12P Reference Manual



5.41 Function 51, filling needle set-up

51. Filling needle set-up

If a system is connected to movable filling needles a special set-up is required for the system, this is done using Function 51.

Today, there are two systems for movable filling needles.

Dumping needle:

A system which lowers the filling needle into the bottle during the filling. The filling needle remains lowered throughout the filling. This system does not require set-up in Function 51.

Bottom-up filling:

A system which lowers the filling needle to the bottom of the bottle before the drive is started. When the drive is started, the filling needle moves slowly upwards, adjusted in such a way that the filling needle follows the liquid.

When the filling is completed, the filling needle will retract quickly.

This system requires set-up in Function 51.

Filling needle set-up is chosen by a number depending on the system.

None	= 0	
Pneumatical Dumping needle	= 0	Can be connected to individual drive
Pneumatical Bottom-up filling	= 1	(many per system)
Electrical Dumping needle	= 2	Must be connected to MC12
Electrical Bottom-up fillin	= 3	(only 1 per system)

As it appears from the above, pneumatical dumping needle does not require set-up by function 51.

MC12P Reference Manual



Pneumatical bottom-Up

If 1 is selected, the system will ask for the drive number that the filling needle should follow.

F51 NEEDLE-TYPE:	1_	1
F46: 2 LANGUAGE	F47: PRINTER-SETUP	
F48: RS232-SETUP	F49: BALANCE SETUP	
F51: NEEDLE	F53: DRIVES ON/OFF	

Fig. 62

F51 FOLLOW DRIVE	0_	1
F46: 2 LANGUAGE	F47: PRINTER-SETUP	
F48: RS232-SETUP	F49: BALANCE SETUP	
F51: NEEDLE	F53: DRIVES ON/OFF	

Fig. 63

The drive number is entered followed by <ENT>, and the system will go into set-up position.

F51SET-UP(0:DOWN/:UP):_	1
F46: 2 LANGUAGE	F47: PRINTER-SETUP
F48: RS232-SETUP	F49: BALANCE SETUP
F51: NEEDLE	F53: DRIVES ON/OFF

Fig. 64

The set-up position makes it possible to adjust the filling needle mechanically when connected to MC12.

When <0> is entered, the filling needle moves to its lowest point and remains there.

When <1> is entered, the filling needle moves to its highest point and remains there.

When the mechanical adjustment of the filling needle is finished, press <ENT> and the set-up procedure is completed and the system will control the connected bottom-up filling system.

MC12P Reference Manual



Electrical dumping needle, Needle type 2

Needle type 2 is selected when a Flexicon electrical dumping needle system is used. This is operated as needle type 1 (see pneumatical bottom up) with the following addition:

- After entering drive number the needle should follow, the MC12 asks for a transport speed by displaying:

F51 TRANSPORT SPEED (mm/sec): 30_	1
F47: PRINTER-SETUP	
F48: RS232-SETUP	F49: BALANCE SETUP
F51: NEEDLE	F53: DRIVES ON/OFF

Fig. 65

The transport speed is the speed by which the needle moves up and down when NOT filling. The speed is set in millimetres/sec.

Electrical bottom-up filling, Needle type 3

Needle type 3 is selected when a Flexicon electrical bottom-up system is used. This is operated as needle type 1 (see pneumatical bottom up) with the following additions:

- After entering drive number the needle should follow, the MC12 asks for a transport speed by displaying:

F51 TRANSPORT SPEED (mm/sec): 30_	1
F47: PRINTER-SETUP	
F48: RS232-SETUP	F49: BALANCE SETUP
F51: NEEDLE	F53: DRIVES ON/OFF

Fig. 66

The transport speed is the speed by which the needle moves up and down when NOT filling. The speed is set in millimetres/sec.

- The MC12 then asks for a fill speed by displaying:

F51 FILL SPEED (mm/sec): 30_	1
F47: PRINTER-SETUP	
F48: RS232-SETUP	F49: BALANCE SETUP
F51: NEEDLE	F53: DRIVES ON/OFF

Fig. 67

MC12P Reference Manual



The fill speed is the speed by which the needle moves upward while filling. The speed is set in millimetres/sec.

- The set-up menu is then shown. The purpose here is to run a test on needle after it has been positioned mechanically:

F51 SET-UP (0:DOWN / 1:UP):	1
F47: PRINTER-SETUP	
F48: RS232-SETUP	F49: BALANCE SETUP
F51: NEEDLE	F53: DRIVES ON/OFF

Fig. 68

This operates as described in this manual with one addition. When <2> is entered, the speed is reduced with 1mm/sec, and when <3> is entered, the speed is increased with 1mm/sec.

- The last menu displays the text:

F51 FILL SPEED (2:DEC/3:INC): 30_	1
F47: PRINTER-SETUP	
F48: RS232-SETUP	F49: BALANCE SETUP
F51: NEEDLE	F53: DRIVES ON/OFF

Fig. 69

Here it is possible to start the filling sequence by <disp><GO> and then trim the fill speed (speed of needle moving upwards) to follow the product surface by pressing <2> for reduced speed or <3> for increased speed. The actual fill speed is shown in millimetres/sec.

MC12P Reference Manual



5.42 Function 53, drive deactivation

53 Drive deactivation

If several drives are connected to the system and parallel or serial fills are to be carried out with fewer drives than those connected, some of the drives must be deactivated.

<5>+<3>+<ENT>

In Function 53 the system will display the number of each connected drive.

Press <Y> for an active drive.

Press <N> for deactivation of the drive.

F53 DRIVE NO.: 1 ACTIVE (Y/N): _	I 1
F46: 2 LANGUAGE	F47: PRINTER-SETUP
F48: RS232-SETUP	F49: BALANCE SETUP
F51: NEEDLE	F53: DRIVES ON/OFF

Fig. 70

The system will then go on to the next connected drive and require the same information for that drive.

F53 DRIVE NO.: 2 ACTIVE (Y/N): _	I 1
F46: 2 LANGUAGE	F47: PRINTER-SETUP
F48: RS232-SETUP	F49: BALANCE SETUP
F51: NEEDLE	F53: DRIVES ON/OFF

Fig. 71

When the system has gone through all connected drives, it will leave Function 53.

The next time Function 53 is called, it is possible to connect the deactivated drives again.

MC12P

Reference Manual



5.43 Function 58 Set Passwords

This function will enable the supervisor to key in passwords for the 3 levels. By entering function 58, the command line will first prompt for password for level 1, key in the 4 digits and press ENT, the command line will then prompt for level 2 and so on for level 3. You have now entered the three passwords and are still in access level 1.

Passwords can be only be erased by entering function 58 in access level 1 and manually deleting the entered passwords.

Passwords must consist of 4 digits and be different for the 3 levels

5.44 Function 59 Change access level

By entering function 59, the command line will prompt for a password. Key in the 4 digits password from Function 58 for the desired access level for the operator and press ENT. Password protecting the MC12 is realised by establishing 3 Levels of operability from the keyboard.

The idea is to limit the number of functions and key's available to the operator. In praxis the operator will have no response from the MC12, when trying to use functionality that have been excluded in the current level.

Level 1:	This is the unlimited operation and programming mode for the MC12. All function are available and all keys are accepted.
Level 2:	This level has the basic functionality enabled on the MC12.
	<GO>: Used when turning on the MC12 and starting a manual filling.
	<DISP>: Used to set the MC12 in dispense mode, so that a filling can be started by pressing <GO> or by external GO signals.
	<STOP>: Used to stop a filling sequence by pressing once or stopping in the middle of a filling by pressing twice.
	<calib> This crucial function is necessary to let the MC12 adjust the volume that is filled.
	Function 59: This Function is always enabled, so that password-levels can be changed.
Level 3:	This level is the most basic operation mode with only <calib.> and Function 59 enabled, so the only way to control the MC12 is by external signals i.e. by external equipment PLC or likewise.

When the MC12 is in Level 2 or 3 and parameters are to be changed or another programme to be loaded, the supervisor must use Function 59 and key in the password for Level 1. Then make the changes and use Function 59 again to put the MC12 back in Level 2 or 3.

MC12P Reference Manual



5.45 Function 60, Ext. Input Mode

Using function 60 it is possible to choose how to use foot-switch.

- 1= Foot-switch operates only as start
- 2= Pushing once makes a start
Pushing second time makes a stop
Pushing third time makes a start.

F60: EXT. INPUT MODE: I _	F53: DRIVE ON/OFF
F51: DUMPING NEEDLES	F80: RESET

Fig. 72

5.46 Function 70, Capacity format

The number of fills carried out by the system can be measured per hour or per minute.

- 1 = Fills per minute
- 2 = Fills per hour

F70 CAPACITY FORMAT: 1_	I 1
F46: 2 LANGUAGE	F47: PRINTER-SETUP
F48: RS232-SETUP	F49: BALANCE SETUP
F51: NEEDLE	F53: DRIVES ON/OFF

Fig. 73

Enter the required output format followed by <ENT> and it will be displayed in Function 10.

Function 70 is not shown in the status lines of the display.

MC12P Reference Manual



5.47 Function 71, flow rate format

71. Function 12, read out

The function reads out the current flow rate in the system when the rotor is running with the programmed number of revolutions per minute.

This flow format can be read out in the following units:

- | | |
|----------------------------|----------------------|
| 1 = millilitres per minute | 4 = litres per hour |
| 2 = millilitres per hour | 5 = kilos per minute |
| 3 = litres per minute | 6 = kilos per hour |

F71 FLOW FORMAT: _	1
F46: 2 LANGUAGE	F47: PRINTER-SETUP
F48: RS232-SETUP	F49: BALANCE SETUP
F51: NEEDLE	F53: DRIVES ON/OFF

Fig. 74

The system will only accept a number from 1 to 6 as described above.

Enter the required format followed by <ENT> and the system will apply the chosen flow rate format for readouts in Function 12.

5.48 Function 72, Volume format

72. Volume format for function 1 and 11.

The function makes it possible to change volume format between volume(ml) and weight(g). This is effective in function 1 and 12 as well as in print out.

1: ml 2: g

F72 VOLUME FORMAT: _	1
F70: CAP. -FORMAT	F71: FLOW FORMAT
F72: VOL. -FORMAT	F80: RESET

Fig. 75

When the value 2 is chosen, the F9 is automatically set to 1.0000 g/ml and can not be changed.

MC12P Reference Manual



5.49 Function 80, reset memory

80. Reset memory

This function will reset the memory with the exception of the part used for saving programs.

The MC12 will enter stand-by mode, and when switched on again the built-in parameters will be valid.

IF THE MC12 DOES NOT WORK OR DOES NOT OPERATE AS EXPECTED, ACTIVATE FUNCTION 80.

A **calibration** is necessary after using function 80.

5.50 Function 86, complete memory reset

86. Complete reset of memory

This function works in the same manner as Function 80 but includes also the part of the memory containing programs saved via Function 31.

This function should only be used for extreme cases.

Function 86 is not shown in the status lines of the display. A **calibration** is necessary after using function 86.

MC12P

Reference Manual



6: DAILY USE

6.1 Used as a dispenser

Switch on the pump PD12I. Switch on the MC12 and press <GO> twice.

Program example using the PD12I:

Volume: 8.5 ml.
Tube: 3.2.
Velocity: 400 rpm.
Acceleration: 35.
Small back suction.
100 fills to be completed.
A delay of 1.1 seconds between the fills.
Product has a spec. gravity 1.0
The above job should be programmed as follows:

Volume: <1>+<ENT>+<8>+<. >+<5>+<ENT>
Tube: <2>+<ENT>+<3>+<. >+<2>+<ENT>
Velocity: <3>+<ENT>+<4>+<0>+<0>+<ENT>
Acceleration: <4>+<ENT>+<3>+<5>+<ENT>
Back suction: <5>+<ENT>+<1>+<ENT>
Number of fills: <6>+<ENT>+<1>+<0>+<0>+<ENT>
Delay: <7>+<ENT>+<1>+<. >+<1>+<ENT>
Specific Gravity <9>+<ENT>+<1>+<. >+<0>+<ENT>

You have now programmed the MC12 for the job but want to reset the built-in counters. The counters indicate "number of completed fills" in Function 8 and "total volume completed" in Function 12.

Number of fills: <8>+<ENT>+<C>+<ENT>
Total volume: <12>+<ENT>+<C>+<ENT>

Now tell the MC12 that you want to enter filling mode by pressing <disp.>.

Every time <GO> or the foot switch is pressed, or every time an electric signal is given, the drive will run 100 fills of 8.5 ml with a delay of 1.1 seconds between each fill.

Press <GO>, check that the drive starts and let it run.

Press Arrow Down twice, and the status lines will show that Function 8 and Function 12 are counting each fill. Function 10 continuously shows the number of fills completed per minute.

MC12P

Reference Manual



6.2 Terminate dispensing

When the drive has completed the number of fills asked for in Function 6 it will stop automatically. If <GO> is pressed again, the drive will complete the programmed number of fills once more.

If you want to stop the filling before the programmed number has been completed, press <STOP>, and the drive will stop after completing the fill in progress.

The filling series can be completed by pressing <GO>.

If you want to stop IMMEDIATELY, such as in the middle of a fill, press <STOP>+<STOP>, and the drive will stop immediately.

The filling series can be completed by pressing <disp.>+<GO>, and the interrupted filling will be included.

6.3 Used as a transfer pump

The MC12 can also be used as a pump controller for which purpose only, velocity should be entered.

The pumping is started by pressing <pump>+<GO>.

The drive will start with the entered acceleration and run up to the required number of revolutions per minute. The drive will pump at this velocity until stopped by pressing <STOP>.

In Function 11 the current uncalibrated flow can be read.

If an exact flow read-out is required, the system must be calibrated. This calibration should be carried out as described in chapter 7: CALIBRATION.

It is recommended to use a rather long fill for this calibration of the flow value.

MC12P

Reference Manual



7: CALIBRATION

As the environment of the MC12 may vary from time to time and as tubes and products have small tolerances, it is necessary to calibrate the drive when it is started. Recalibration is necessary during production.

If the quantity has been entered as volume in ml, a measuring cylinder or a balance may be used as a control and measuring unit. The balance will always be the more accurate, especially for small quantities.

7.1 Calibration with measuring cylinder

(The parameters already entered may be used for a trial).

Prepare the measuring cylinder and make sure that the tubes are completely filled, up to and including the filling needle. (It is recommended to let the drive complete a few fills before the calibration is carried out. After these fills, reset Function 8 and Function 11).

Keep the measuring cylinder below the filling needle and press <calib.>+<GO>. The drive will complete ONE trial fill, and the display will now show the following:

CALIBRATION WEIGHT:	0.0000_	l 1
F 1: 8.00 ml.	F 2: 6.0 TUBE	
F 3: 200 rpm	F 4: 10 ACC	
F 5: 0 REV	F 6: 1 fills	

Fig. 76

In the prompt line the MC12 asks for the weight, but as a measuring cylinder is used THE VOLUME MUST BE ENTERED i.e. when F9 specific gravity = 1.0000 g/ml, e.g. 8.05:
<8>+<. >+<0>+<5>+<ENT>.

The calibration is now completed and the filling may be started by pressing <disp.>+<ENT>.

MC12P Reference Manual



7.2 Calibration with balances

(The parameters already entered may be used for a trial).

Prepare the balance by tarring the container (bottle) to be used for the trial fill and make sure that the tubes are completely filled, up to and including the filling needle. (It is recommended to let the drive complete a few fills before the calibration is carried out. After these fills, set F9, reset Function 8 and Function 11).

Keep the container below the filling needle and press <calib.>+<GO>. The drive will complete ONE trial fill, and the display will now show the following:

CALIBRATION WEIGHT:	0.0000	1
F 1: 8.50 ml.	F 2: 8.0 TUBE	
F 3: 200 rpm	F 4: 10 ACC	
F 5: 0 REV	F 6: 1 fills	

Fig. 77

In the prompt line the MC12 asks for the weight, and the value shown on the balance must be entered, e.g. 8.25: <8>+<. >+<2>+<5>+<ENT>.

Specific gravity is entered at F9.

Calibration is now completed and the filling may be started by pressing <disp.>+<ENT>.

MC12P Reference Manual



7.3 Calibration of grams with balance

A MC12 programmed to fill a quantity measured in grams must be calibrated by means of a balance.

(The parameters already entered may be used for a trial, where the 8.5 ml equals 8.5 grams).

Prepare the balance by tarring the container (bottle) to be used for the trial fill and make sure that the tubes are completely filled up to and including the filling needle.

(It is recommended to let the drive complete a few fills before the calibration is carried out. After these fills, reset Function 8 and Function 11).

Keep the container below the filling needle and press <calib.>+<GO>. The drive will make ONE trial fill, and the display will now show the following:

CALIBRATION WEIGHT:	0.0000_	1 1
F 1: 8.50 g.	F 2: 4.8 TUBE	
F 3: 200 rpm	F 4: 10 ACC	
F 5: 0 REV	F 6: 1 fills	

Fig. 78

In the prompt line the MC12 asks for the weight, and the value shown on the balance must be entered, e.g. 8.25: <8>+<. >+<2>+<5>+<ENT>.

Since weight is used as measuring unit instead of volume, THE SPECIFIC GRAVITY WILL ALWAYS BE 1 regardless of the specific gravity of the product.

The MC12 has now automatically adjusted the value from 8.25 g to 8.5 g, and the filling may be started by pressing <disp.>+<ENT>.

MC12P Reference Manual



7.4 Recalibration

During production it may be necessary to recalibrate the volume dispensed by the drive to compensate for changes in the environment, e.g. the liquid level of the feed vessel will sink. The natural wear of tubing may also cause need for recalibration. This recalibration can be made without stopping filling.

IT IS IMPORTANT TO USE THE SAME MEASURING METHOD FOR THE RECALIBRATION AS WAS USED FOR THE INITIAL CALIBRATION.

Tare the bottle on balance and take a filling sample from the drive.

Weigh the sample.

Press <Calib.>+<ENT>.

Enter the measured value, e.g. 8.47: <8>+<.>+<4>+<7>+<ENT>, and the MC12 will now automatically correct the drive from 8.47 to 8.5 as required.

RE CALIBRATION WEIGHT.	0.0000_	1 1
F 1: 8.50 ml.	F 2: 8.0 TUBE	
F 3: 200 rpm	F 4: 10 ACC	
F 5: 0 REV	F 6: 1 fills	

Fig. 79

The MC12 takes into account the value of F9 when recalibrating.

MC12P Reference Manual



7.5 Calibration in parallel mode

When the MC12 operates with several drives in the parallel mode, the system is controlled from **Drive 0**.

ENTER DRIVE NO.	0_	P0
F 1: 100.00 ml.	F 2: 8.0 TUBE	
F 3: 200 rpm	F 4: 10 ACC	
F 5: 0 REV	F 6: 1 fills	

Fig. 80

Select the parallel mode by using function 40.

Let the drives complete a few fills before the calibration is carried out.

Stop the drives by pressing <STOP> on MC12.

Tare a bottle on balance.

Press <Calib>+<Go>. The MC12 will ask for drive number.

Hold the bottle under the filling needle connected to the drive to be calibrated and enter the drive no. and press <ENT>.

The drive will carry out a filling.

Weigh the bottle and enter the value shown by balance. Drive is now ready to be started.

Press <disp.>+<Go>.

Repeat 5 to 9 for all drives connected in parallel.

After the drives have run a period of time they should be recalibrated manually.

Tare the bottle on balance and take a filling sample from the drive.

Weigh the sample.

Press <Calib.>+<ENT>.

MC12 will ask for drive no.

Enter the number for the drive in question and press <ENT>.

Enter the value shown on balance into MC12.

Repeat the above for all drives connected in parallel.

MC12P

Reference Manual



7.6 Calibration in serial mode

When the MC12 operates with several drives in the serial mode, the system is controlled from **Drive 0**.

In connection with calibration or recalibration, the MC12 will regard all drives as one single filler.

If a new set up in serial mode is desired, then it is recommended that **function 80** is applied. After resetting and setting the parameters such as F1, F3, F4, F6, F7, F9 etc. Select the serial mode (see description for function 40). Use function 41 to select the first drive in order to ensure that the correct tubing size is entered. Repeat for all the drives connected in serial. Shift back to drive 0.

Tare a bottle on balance.

Hold the bottle under the first filling station and press <Calib.>+<Go>. All drives will dispense once.

MC12 will ask for calibration weight. Do not enter any value and confirm the value shown (0.0000) on display by pressing <ENT>.

Hold the bottle under the second filling station and press <Calib.>+<Go>. All drives will dispense once.

MC12 will ask for calibration weight. Do not enter any value and confirm the value shown (0.0000) on display by pressing <ENT>.

Repeat 4 to 5 for the drives except the last drive in connection.

Hold the bottle under the third filling station and press <Calib.>+<Go>. All drives will dispense once.

When the filling from last station is completed the bottle is weighed and the value is entered in MC12.

MC12 makes the necessary adjustment of volume.

MC12P Reference Manual

7.7 Dynamic recalibration:

Use function 49 to set up the balance. (See description of function 49).

Tare a bottle and hold under filling station.

Press <Calib.>+<Go>.

Weigh the filling volume.

Enter the value in MC12 and press <ENT>.

Start the production by pressing <Disp.>+<Go>.

Tare the bottle and take a filling sample.

Place the bottle on the balance and wait for the beep sound. If no beep is generated, the value is much lower than the nominal value and probably outside the recalibration window (see below).

Tare the bottle and take a filling sample.

Place the bottle on the balance and wait for the beep sound. If a short beep is generated the MC12 has captured the weight.

The illustration below shows the correlation between the terms used in dynamic recalibration and the beeps generated by system.

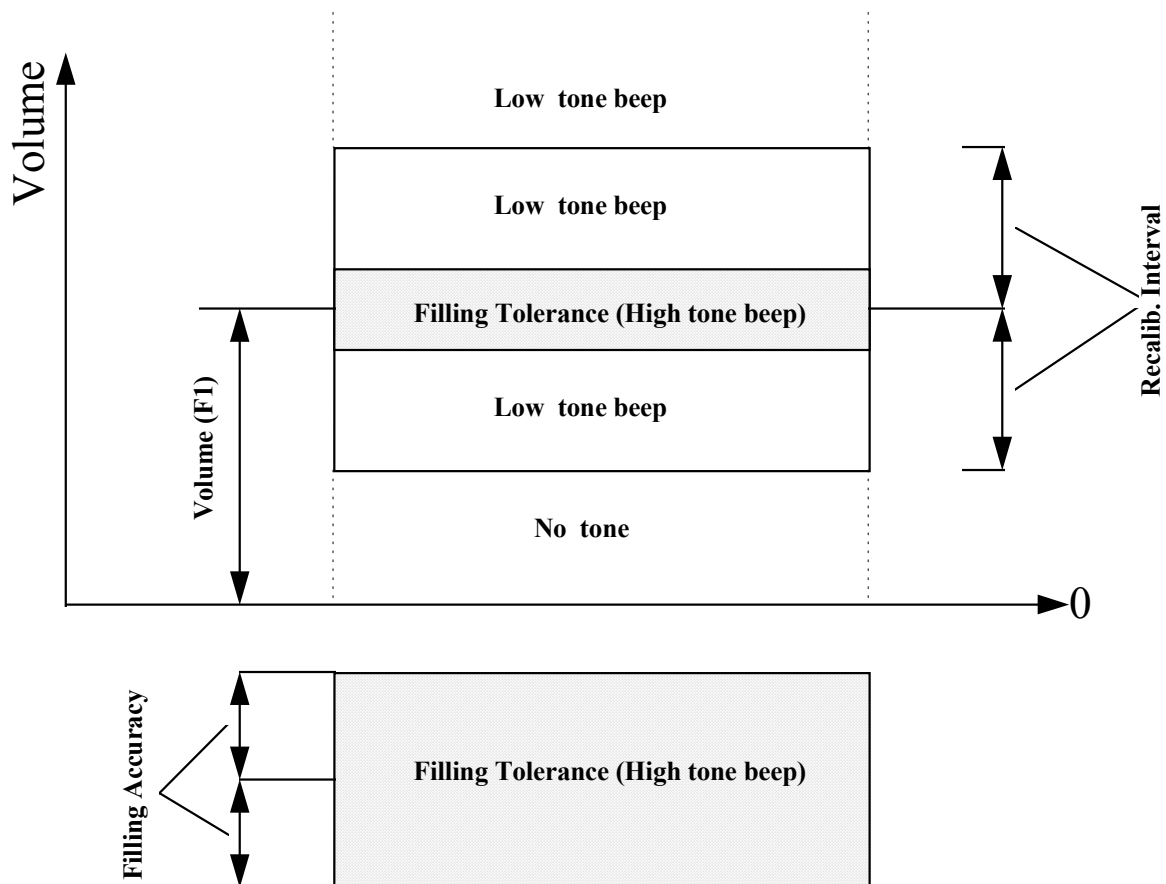

Fig. 81

MC12P

Reference Manual



7.8 Fill on balance.

When fill on balance has been selected the filling sequence is operated by putting a bottle on the balance. Tare the balance and start the filling by entering <disp.><GO>. The filling sequence now runs interactively with registration of the weight from the balance. During the last part of the fill the drive will run slowly and it will have a number of stops while it is waiting for a weight registration from the balance. When the filling is ended the MC12 gives a beep. When the MC12 is set to fill on balance, this is indicated by a "F" in the upper right corner of the display.

Procedure for filling interactively with balance.

Prime the drive in order to fill the tubes.

Press <Calib.>+<Go>

Put the bottle on balance and tare.

Press <disp.>+<Go>

Wait for the MC12 to generate a beep. The beep sound is indication for filling completion.

MC12P Reference Manual



8: CLEANING AND MAINTENANCE

8.1 Daily cleaning

As the MC12P is not in direct contact with the dispensed product, daily cleaning will not be necessary except for the normal routine cleaning of production equipment.

The control panel is made of anodized aluminium and plastics, and normal detergents as spirit and isopropanol may be used.

8.2 Sterilisation

If the MC12P is placed in an aseptic environment, the sterilization may be made as described in paragraph 8.1, or the MC12P may be sterilised with gases observing the following precautions.

If gases are used that might have a detrimental effect on contacts and other metals, air slots and sockets **MUST** be covered with tape.

8.3 Maintenance

As there are no movable parts in the MC12P, no maintenance is required apart from normal cleaning of the equipment.

If service should be needed, please contact Flexicon A/S or your local supplier.

MC12P Reference Manual

9: INTERFACE

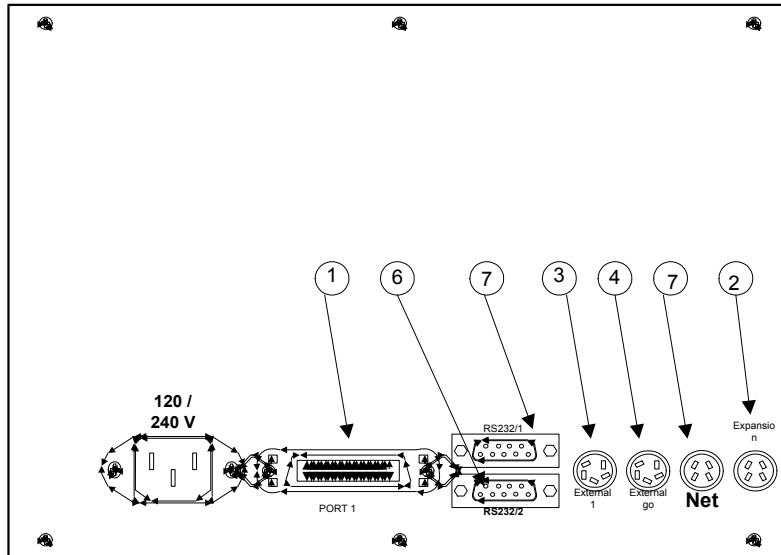

Fig. 80

The MC12P has 7 interface ports.

- (1) "port 1"
- (2) "expansion"
- (3) "external GO"
- (4) "external 1"
- (5) "RS-232/1"
- (6) "RS-232/2"
- (7) "Net"

9.1 "port 1", Fig. 80.1

Socket for Flexicon peripheral equipment such as the bottom-up filling system. The socket may only be used in connection with original Flexicon equipment.

9.2 "expansion", Fig. 80.2

Socket for extensions. Only to be used in connection with original Flexicon equipment.

MC12P Reference Manual



9.3 "external GO", Fig. 80.3

- Pin 1. Input for start signal.
+5 +50 Vdc, min. 100 msec. Front triggered.
- Pin 2. Output, +24 Vdc, max 250 mA.
- Pin 3. Ground.
- Pin 4. Status output, max. +50 Vdc, 250 mA.
Pin 4 is earthed via a relay when a connected drive is active.
Follows the displayed drive.
- Pin 5. No connection.

9.4 "external 1", Fig 80.4

- Pin 1. Input for start signal.
+5 +50 Vdc, min. 100 msec. Front triggered.
- Pin 2. Output, +24 Vdc, max 250 mA.
- Pin 3. Ground.
- Pin 4. Status output, max. +50 Vdc, 250 mA.
Pin 4 is earthed via a relay when a connected drive is not active.
Follows the displayed drive.
- Pin 5. No connection.

9.5 "RS-232/1", Fig. 80.5

- Pin 2. Receive data
- Pin 3. Transmit data
- Pin 4. +12 Vdc (1KOhm)
- Pin 5. Ground
- Pin 7. Request to send
- Pin 8. Clear to send

9.6 "RS-232/2", 80.6

- Pin 2. Receive data
- Pin 3. Transmit data
- Pin 4. +12 Vdc (1KOhm)
- Pin 5. Ground
- Pin 7. Request to send
- Pin 8. Clear to send

9.7 "net", Fig. 80.7

The "net" socket is reserved for RS-485 communication with the connected drives. Communication may only take place via original Flexicon cables marked "TYPE 3".

MC12P Reference Manual

9.8 Change of voltage

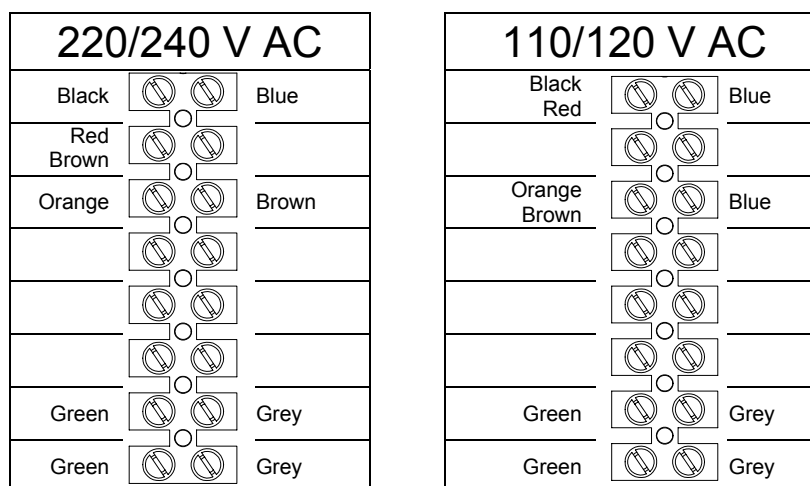

Fig. 81

The MC12P can be converted to accept another supply voltage.
The conversion can be made inside the machine by moving the cables on the transformer clamps.

COPYRIGHT

Copyright (c) 2004 Flexicon A/S. All rights to this manual belong to Flexicon A/S. Neither the complete manual nor parts of it may be translated, copied, printed or published in any form or by any means without permission in writing from Flexicon A/S

Flexicon A/S is convinced that the information of this manual is correct, but Flexicon A/S can not be held responsible for it.

Flexicon A/S reserves the right to update and amend this manual without previous notice. Flexicon A/S is under no obligation to update manuals already published.